

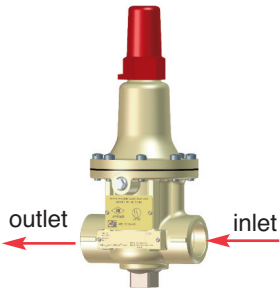

— MODEL — **55L-60**

Pressure Relief Valve/ Pump Casing Relief Valve

**1/2" and 3/4"
Globe
Configuration**



0-75 psi
20-200 psi
20-300 psi



100-300 psi

**1/2", 3/4" and 1"
Angle Configuration**

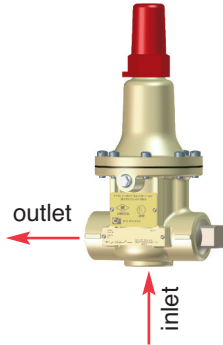

1" Size
20-75 psi
40-200 psi
100-300 psi

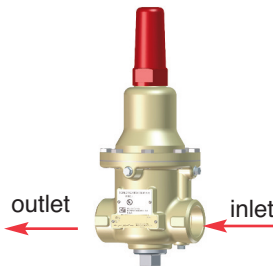

more materials
available

- Sizes 1/2" and 3/4" are UL Listed and FM Approved for use as Fire Pump Casing Relief Valves
- The 1" model is UL Listed for use as a Fire Pump Casing Relief Valve
- Direct Acting - Precise Pressure Control
- Drip Tight Closure
- No Packing Glands or Stuffing Boxes
- Globe or Angle configurations available
- Sensitive to Small Pressure Variations
- Meets low lead requirements
- Available in Cast Bronze, 316 Stainless Steel, Monel & Super Duplex Stainless Steel

The Cla-Val Model 55L-60 (UL Listed, FM Approved) Pressure Relief Valve is a direct-acting, spring loaded, diaphragm type relief valve. The valve may be installed in any position and will open and close within very close pressure limits. The bottom plug may be removed and installed in the inlet to convert it to an angle pattern flow path.

The Model 55L-60 is normally held closed by the force of the compression spring above the diaphragm. When the controlling pressure applied under the diaphragm exceeds the spring setting, the disc is lifted off its seat, permitting flow through the control. When control pressure drops below the spring setting, the spring forces the control back to its normally closed position. The controlling pressure is applied to the chamber beneath the diaphragm through an internal passage. A gauge port is provided for accurate pressure setting.

Pressure adjustment is done by turning the adjusting screw to vary the spring load on the diaphragm. The 55L-60 is available in pressure ranges suited to agency approval tests. To prevent tampering, the adjustment cap can be wire sealed by using the lock wire holes provided in the cap and cover.



Fire Protection System Service

The **Model 55L-60** is typically used in a fire protection system to trim water pressure, thus preventing pressure build-up whenever line pressure exceeds the setting of the spring.

The 55L-60 will relieve excess pressure to atmosphere to prevent damage to the distribution network.

NOTE: Model 55L-60 is not suitable for discharging the full-rated pump capacity of a fire pump. See Model 50B-4KG1 Fire Pump Relief Valve for such applications.

Typical Application for Fresh Water or Seawater Service

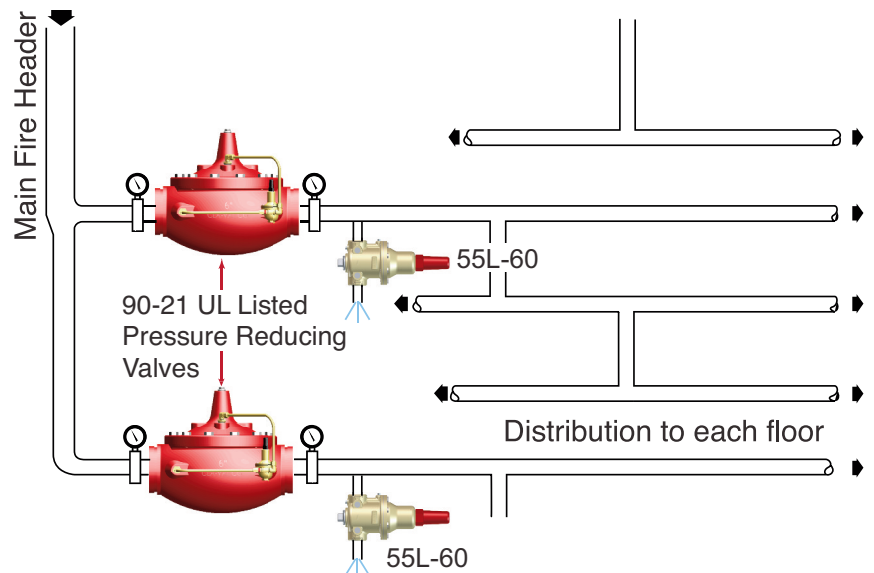

Specifications

Size	1/2", 3/4" and 1" Threaded NPT
Temperature Range	Water, Air: to 180°F Max.
Materials	
Body & Cover:	Cast Bronze UNS C87850 -Standard Stainless Steel ASTM A743-CF-16F Monel Super Duplex Stainless Steel
Trim:	303 Stainless Steel Monel
Rubber:	Buna-N® Synthetic Rubber
Pressure Ratings	Cast Bronze 400 psi Max. Stainless Steel 400 psi Max.
Other Materials	Available on special order

Adjustment Ranges UL Listed

10 to 75 psi • 20 to 200 psi • 20 to 300 psi • 100 to 300 psi

Adjustment Ranges FM Approved

0 to 75 psi • 20 to 200 psi • 20 to 300 psi • 100 to 300 psi

Pressure Drop Chart (Full Open Valve)

Valve Size	C _v Factor	Max Flow (GPM)
1/2"	6	25
3/4"	8.5	40
1"	12.8	65

Standard Factory Set Points* (1/2", 3/4", 1")

0 -75 psi	20 - 200 psi	20 - 300 psi	100 - 300 psi
50 psi	60 psi	60 psi	100 psi

* Custom set points available upon request

When Ordering, Please Specify

1. Catalog No. 55L-60
2. Valve Size
3. Adjustment Range Desired
4. Optional Materials

Dimensions (1/2" and 3/4")

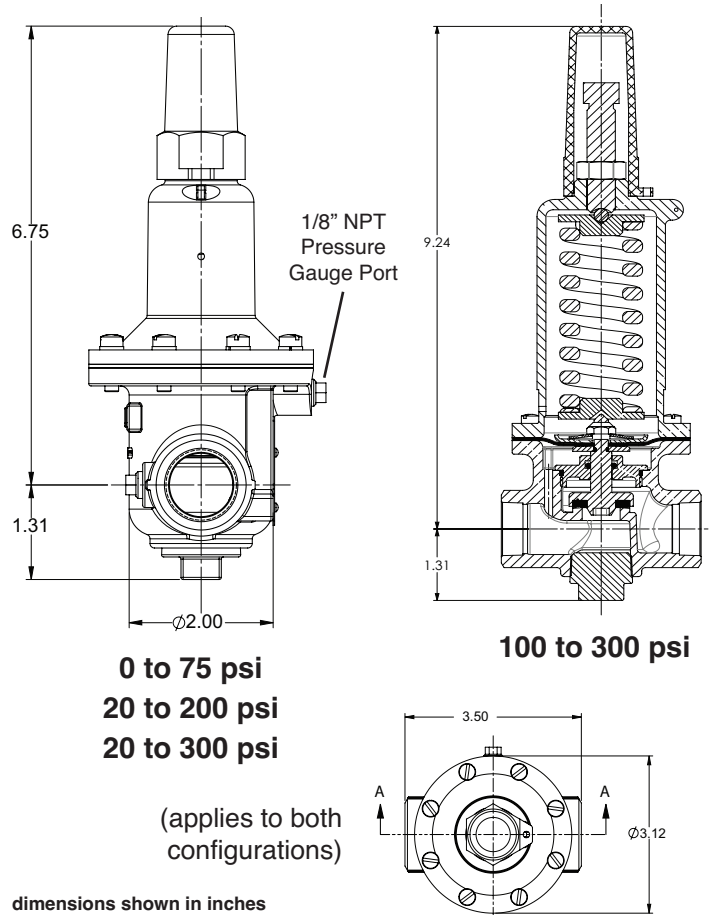

Dimensions (1"):

Spring Range:

20-75
40-200
100-300

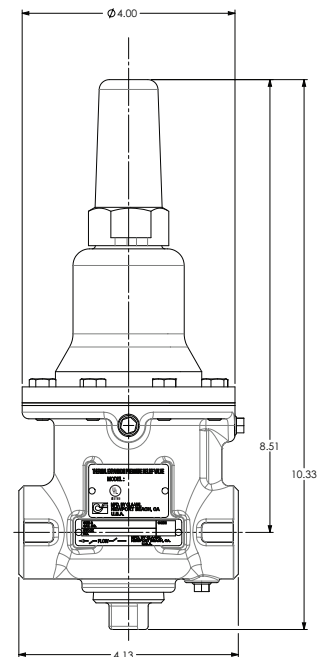

E-55L-60 (R-03/2021)

CLA-VAL

1701 Placentia Avenue • Costa Mesa CA 92627
800-942-6326 • Web Site: www.cla-val.com • E-mail: info@cla-val.com

CLA-VAL CANADA
4687 Christie Drive
Beamsville, Ontario
Canada L0R 1B4
Phone: 905-563-4963
www.cla-val.com
E-mail: sales@cla-val.ca

CLA-VAL EUROPE
Chemin des Mésanges 1
CH-1032 Romanel/
Lausanne, Switzerland
Phone: 41-21-643-15-55
www.cla-val.ch
E-mail: cla-val@cla-val.ch

CLA-VAL UK
Dainton House, Goods Station Road
Tunbridge Wells
Kent TN1 2 DH England
Phone: 44-1892-514-400
www.cla-val.ch
E-mail: info@cla-val.ch

CLA-VAL FRANCE
Porte du Grand Lyon 1
ZAC du Champ du Pérrier
France - 01700 Neyron
Phone: 33-4-72-25-92-93
www.cla-val.ch
E-mail: cla-val@cla-val.ch

CLA-VAL ASIA PACIFIC
45 Kennaway Road
Woolston, Christchurch, 8023
New Zealand
Phone: 64-39644860
www.cla-valpacific.com
E-mail: info@cla-valpacific.com